

2502

Fiber Alignment Photodiode Meter

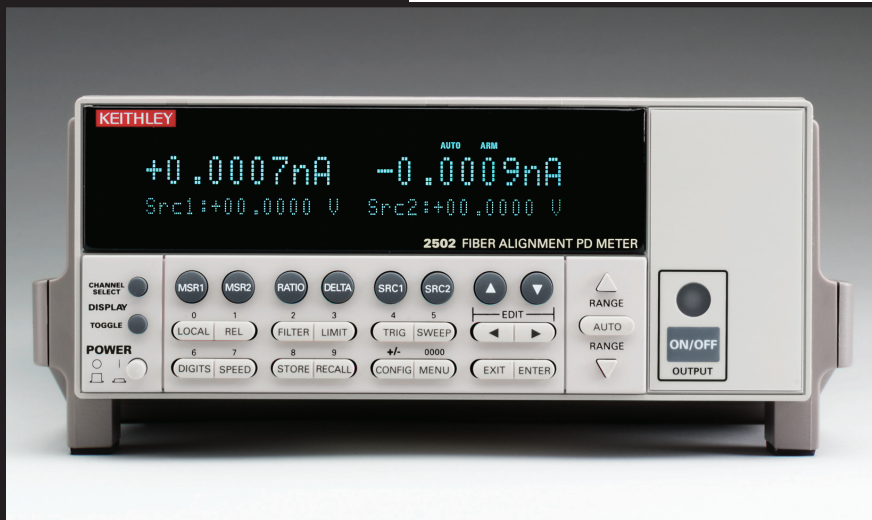

The Model 2502 Photodiode Meter is designed to increase the throughput of Keithley's LIV (light-current-voltage) test system for production testing of laser diode modules (LDMs). Developed in close cooperation with leading manufacturers of LDMs for fiberoptic telecommunication networks, these dual-channel instruments have features that make them easy to synchronize with other system elements for tight control over optical power measurements. The Model 2502 features a high speed analog output that allows using the LIV test system at the fiber alignment stage of the LDM manufacturing process. Through the use of buffer memory and a Trigger Link interface that's unique to Keithley instruments, the Model 2502 can offer the fastest throughput available today for LIV testing of laser diode modules. These instruments are ruggedly engineered to meet the reliability and repeatability demands of continuous operation in round-the-clock production environments.

- Dual-channel instrument for optical power measurements
- $\pm 100\text{V}$ photodetector bias capability
- Measure photodetector current from 1fA to 20mA
- 1fA dark current measurement resolution
- Measure optical power directly when used with Model 2500INT Integrating Sphere
- $0\text{--}10\text{V}$ analog output for high resolution optical power feedback
- Provides a high accuracy, high speed fiber alignment solution
- Allows assembly process, final testing, parts binning, and specification
- Allows faster alignment of the fiber with the laser diode's optimum light emitting region
- Combines fiber alignment and device characterization processes
- User-programmable photodetector calibration coefficients
- 3000-point buffer memory on each channel allows data transfer after test completion
- Digital I/O and Trigger Link for binning and sweep test operations
- IEEE-488 and RS-232 interfaces

Low-Level, High Speed Measurements

The Model 2502 combines Keithley's expertise in low-level current measurements with high-speed current measurement capabilities. Each channel of this instrument consists of a voltage source paired with a high-speed picoammeter. Each of the two channels has an independent picoammeter and voltage source with measurements made simultaneously across both channels.

Part of a High-Speed LIV Test System

In a laser diode module DC/CW test stand, the Model 2502 provides the voltage bias to both the back facet monitor diode and a Model 2500INT Integrating Sphere or to a fiber-coupled photodetector. At the same time it applies the voltage biases, it measures the current outputs of the two photodetectors and converts these outputs to measurements of optical power. The conversion is performed with the user-programmed calibration coefficient for the wavelength of the laser diode module. Fast, accurate measurements of optical power are critical for analyzing the coupling efficiency and optical power characteristics of the laser diode being tested. When testing modules with multiple detectors, the Model 2502 packs more testing capabilities into less test rack space.

Fiber Alignment

The Model 2502's built-in high speed analog output makes it suitable for precision fiber alignment tasks. This instrument combines the ability to align the optical fiber quickly and accurately with a laser diode's optimum light emitting region and the capability to make precision LIV measurements, all in the same test fixture. The Model 2502's wide dynamic range allows early beam skirt detection, reducing the time required for fiber alignment. An LIV sweep can be performed during the alignment process to optimize fiber location for an entire operating range. High speed feedback minimizes delays in the alignment process, so it's unnecessary to sacrifice alignment speed to ensure accurate device characterization.

Wide Dynamic Measurement Range

The Model 2502 offers current measurement ranges from 2nA to 20mA in decade steps. This provides for all photodetector current measurement ranges for testing laser diodes and LEDs in applications such as LIV testing, LED total radiance measurements, measurements of cross-talk and insertion loss on optical switches, and many others. The Model 2502 meets industry testing requirements for the transmitter as well as pump laser modules.

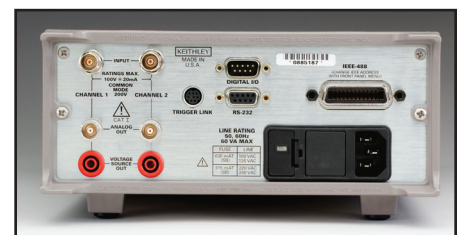

1.888.KEITHLEY (U.S. only)

www.keithley.com
KEITHLEY

A GREATER MEASURE OF CONFIDENCE

2502

Ordering Information

2502 Fiber Alignment Photodiode Meter

Extended warranty, service, and calibration contracts are available.

Accessories Supplied
User's Manual

APPLICATIONS

Production testing of:

- Laser diode modules
- Chip on submount laser diodes
- LEDs
- Passive optical components
- Laser diode bars
- Fiber alignment

Fiber Alignment Photodiode Meter

High Accuracy Dark Current Measurements

The Model 2502's 2nA current measurement range is ideal for measuring dark currents with 1fA resolution. Once the level of dark current has been determined, the instrument's REL function automatically subtracts the dark current as an offset so the measured values are more accurate for optical power measurements.

Voltage Bias Capability

The Model 2502 provides a choice of voltage bias ranges: $\pm 10V$ or $\pm 100V$. This choice gives the system integrator the ability to match the bias range more closely to the type of photodetector being tested, typically $\pm 10V$ for large area photodetectors and $\pm 100V$ for avalanche-type photodetectors. This ability to match the bias to the photodetector ensures improved measurement linearity and accuracy.

High Testing Throughput

The Model 2502 is capable of taking 900 readings/second per channel at $4\frac{1}{2}$ -digit resolution. This speed is comparable with the measurement speed of the Model 2400 SourceMeter instrument, which is often used in conjunction with the Model 2502 to perform optoelectronic device test and characterization. Both instruments support Trigger Link (a proprietary "hardware handshaking" triggering system that's unique to Keithley products) and buffer memory. When programmed to execute a sweep, Trigger Link ensures measurement integrity by keeping the source and measurement functions working in lock step while the buffer memories record the measurements. Together, source memory, buffer memory, and Trigger Link eliminate GPIB traffic during a test sweep, improving test throughput dramatically.

Ratio and Delta Measurements

The Model 2502 can provide ratio or delta measurements between the two completely isolated channels, such as the ratio of the back facet monitor detector to the fiber-coupled photodetector at varying levels of input current. These functions can be accessed via the front panel or the GPIB interface. For test setups with multiple detectors, this capability allows for targeted control capabilities for the laser diode module.

Programmable Limits and Filters

As with most Keithley instruments, the Model 2502's current and voltage limits can be programmed to ensure device protection during critical points such as start of test, etc. These instruments also provide Average and Median filters, which can be applied to the data stored in the buffer memory.

Adaptable to Evolving DUT Requirements

Unlike optical power meters with integrated detectors, the Model 2502 allows the user to choose from a wide range of measurement capabilities simply by selecting an appropriate photodetector and programming the calibration coefficient of this detector at the wavelength of choice.

Interface Options

To speed and simplify system integration and control, the Model 2502 includes the Trigger Link feature and digital I/O lines, as well as standard IEEE-488 and RS-232 interfaces. The Trigger Link feature combines six independent software selectable trigger lines on a single connector for simple, direct control over all instruments in a system. This feature is especially useful for reducing total test time if the test involves a sweep. The Model 2502 can sweep through a series of measurements based on triggers received from the SourceMeter Instrument. The digital I/O lines simplify external handler control and binning operations.

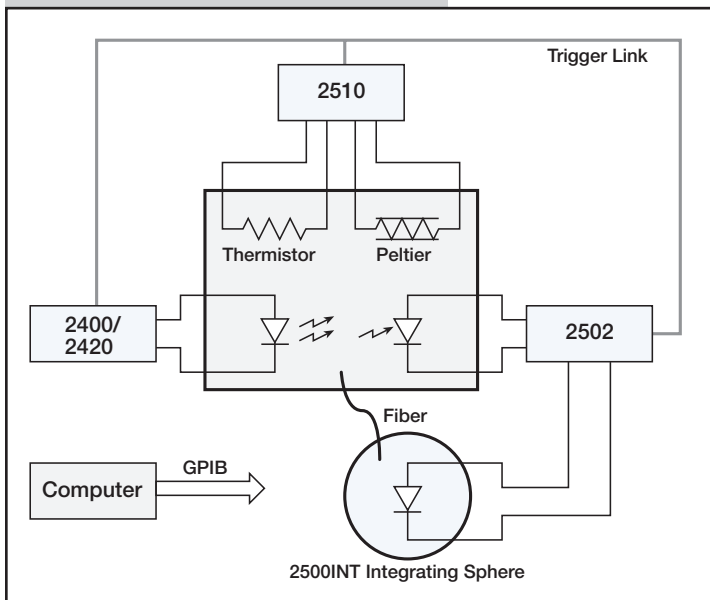

The Model 2502 is designed for tight integration with other Keithley instruments that are often used in LIV test systems for laser diode modules. These other instruments include the Model 2400 SourceMeter and Model 2510 TEC SourceMeter instruments.

Dual channel optical power measurement

OPTOELECTRONIC TEST SOLUTIONS

1.888.KEITHLEY (U.S. only)

www.keithley.com

KEITHLEY

A GREATER MEASURE OF CONFIDENCE

The Model 2502 Dual Photodiode Meter can measure and display either photodiode current or optical power for two photodiodes with appropriate user-supplied optical power gain/wavelength calibration factors.

The Model 2502 includes an analog output jack on the rear panel for each channel.

Measurement Specifications

RANGE	MAXIMUM RESOLUTION	ACCURACY ^{1,2} 23°C ±5°C ±(% rdg. + offset)	TEMPERATURE COEFFICIENT 0°–18°C & 28°–50°C ±(% rdg. + offset)/°C	DC INPUT IMPEDANCE ³ (Maximum)
2.00000 nA	1 fA	1.00% + 2 pA	0.01 + 200 fA	20 kΩ
20.00000 nA	10 fA	0.40% + 2 pA	0.01 + 200 fA	20 kΩ
200.0000 nA	100 fA	0.30% + 200 pA	0.02 + 20 pA	200 Ω
2.000000 μA	1 pA	0.20% + 200 pA	0.02 + 20 pA	200 Ω
20.00000 μA	10 pA	0.10% + 20 nA	0.01 + 2 nA	2.0 Ω
200.0000 μA	100 pA	0.10% + 20 nA	0.01 + 2 nA	2.0 Ω
2.000000 mA	1 nA	0.10% + 2 μA	0.02 + 200 nA	0.2 Ω
20.00000 mA	10 nA	0.10% + 2 μA	0.02 + 200 nA	0.2 Ω

MAXIMUM INPUT: ±20.0mA.

TYPICAL SPEED AND NOISE REJECTION⁴

DIGITS	READINGS/s		NPLC	NMRR
	GPIB (SCPI)	GPIB (488.1)		
4½	700	900	0.01	—
5½	460	475	0.1	—
6½	58	58	1	60 dB

PHOTODIODE VOLTAGE BIAS SPECIFICATIONS²

RANGE	RESOLUTION	ACCURACY 23°C ±5°C ±(0.15% of setting + 5 mV)	MAXIMUM CURRENT	LOAD REGULATION ⁵	TEMPERATURE COEFFICIENT
0 to ±10 V	<400 μV	±(0.15% of setting + 5 mV)	20 mA	< 0.30%, 0 to 20 mA	150 ppm/°C
0 to ±100 V	<4 mV	±(0.3% of setting + 50 mV)	20 mA	< 0.30%, 0 to 20 mA	300 ppm/°C

NOTES:

- Speed = Normal (1.0 NPLC), Filter On.
- 1 year.
- Measured as $\Delta V_{in}/\Delta I_{in}$ at full scale (and zero) input currents.
- Dual channel, internal trigger, measure only, display off, Autorange off, Auto Zero off, source delay = 0, filters off, limits off, CALC5 and CALC6 off, 60Hz.
- Measured as $\Delta V_{in}/\Delta I_{in}$ at full scale (20mA) and zero load currents.
- Noise floor measured as rms (1 standard deviation), 100 samples, Filter off, open (capped) input.
- Specification by design.
- Measured (at input triax) as ΔV_{in} at full scale (20mA) vs. zero input currents.

ANALOG OUTPUT SPECIFICATIONS

OUTPUT VOLTAGE RANGE¹: Output is inverting: –10V out for positive full scale input.
+10V out for negative full scale input.

OUTPUT IMPEDANCE: 1kΩ typical.

GENERAL				
TYPICAL NOISE FLOOR MEASUREMENT SPECIFICATION ⁶				
RANGE	TYPICAL NOISE FLOOR RMS (1 STDEV), 100 SAMPLES			
	0.01 NPLC	0.1 NPLC	1.0 NPLC	10 NPLC
2.000000 nA	2 pA	1 pA	40 fA	15 fA
20.00000 nA	2 pA	1 pA	40 fA	15 fA
200.0000 nA	200 pA	100 pA	2 pA	500 fA
2.000000 μA	200 pA	100 pA	2 pA	500 fA
20.00000 μA	20 nA	10 nA	200 pA	50 pA
200.0000 μA	20 nA	10 nA	200 pA	50 pA
2.000000 mA	2 μA	1 μA	25 nA	5 nA
20.00000 mA	2 μA	1 μA	25 nA	5 nA

SOURCE CAPACITANCE: Stable to 10.0nF typical.
INPUT BIAS CURRENT⁷: 50fA max. @ 23°C.
INPUT VOLTAGE BURDEN⁸: 4.0mV max.
VOLTAGE SOURCE SLEW RATE: 3.0ms/V typical.
COMMON MODE VOLTAGE: 200VDC.
COMMON MODE ISOLATION: Typically 10⁹Ω in parallel with 150nF.
OVERRANGE: 105% of measurement range.
MEMORY BUFFER: 6000 readings (two 3000 point buffers). Includes selected measured value(s) and time stamp.
PROGRAMMABILITY: IEEE-488 (SCPI-1995.0), RS-232, five user-definable power-up states plus factory default and *RST.
DIGITAL INTERFACE:
Enable: Active low input.
Handler Interface: Start of test, end of test, 3 category bits. +5V @ 300mA supply.
Digital I/O: 1 trigger input, 4 TTL/Relay Drive outputs (33V @ 500mA, diode clamped).
POWER SUPPLY: 100V/120V/220V/240V ±10%.
LINE FREQUENCY: 50, 60Hz.
POWER DISSIPATION: 60VA.
WARRANTY: 1 year.
EMC: Complies with European Union Directive 89/336/EEC.
VIBRATION: MIL-T-28800F Random Class 3.
SAFETY: Complies with European Directive 73/23/EEC.
WARM-UP: 1 hour to rated accuracy.
DIMENSIONS: 89mm high × 213mm wide × 370mm deep (3½ in × 8½ in × 14¾ in). **Bench configuration (with handle and feet):** 104mm high × 238mm wide × 370mm deep (4½ in × 9½ in × 14¾ in).
WEIGHT: 23.1kg (10.5 lbs).
ENVIRONMENT:
Operating: 0°–50°C, 70% R.H. up to 35°C non-condensing. Derate 3% R.H./°C, 35°–50°C.
Storage: –25° to 65°C, non-condensing.

RANGE	ACCURACY	TEMPERATURE COEFFICIENT	RISE TIME
	23°C ±5°C ±(%output + offset)	0°–18°C & 28°–50°C ±(%output + offset)/°C	Typical (10% to 90%)
2.000000 nA	6.0% + 90 mV	0.30% + 7 mV	6.1 ms
20.00000 nA	3.0% + 9 mV	0.11% + 700 μV	6.1 ms
200.0000 nA	6.0% + 90 mV	0.30% + 4 mV	395 μs
2.000000 μA	3.0% + 9 mV	0.11% + 400 μV	395 μs
20.00000 μA	6.0% + 90 mV	0.30% + 4 mV	135 μs
200.0000 μA	2.5% + 9 mV	0.11% + 400 μV	135 μs
2.000000 mA	6.0% + 90 mV	0.30% + 4 mV	21 μs
20.00000 mA	2.5% + 9 mV	0.11% + 400 μV	21 μs

¹The analog output voltage for each channel is referenced to that channel's floating ground.

1.888.KEITHLEY (U.S. only)

www.keithley.com

KEITHLEY